

Circuiti e maschere per
Circuit and mask for
Schlauch mit maske für
Circuitos y mascarillas para
Circuitos e máscaras para

Master Flux

Plus

<i>Istruzioni per l'uso</i>	<i>ITALIANO</i>
<i>Instructions for use</i>	<i>ENGLISH</i>
<i>Bedienungsanleitung</i>	<i>DEUTCH</i>
<i>Instrucciones de uso</i>	<i>ESPAÑOL</i>
<i>Instruções manuais</i>	<i>PORTUGUÊS</i>

INDICE

1. DESTINAZIONE D'USO
3. COLLEGAMENTI
4. PULIZIA

1 DESTINAZIONE D'USO

I circuiti e le maschere TECNO-GAZ sono accessori del dispositivo Master Flux, devono essere utilizzate esclusivamente con il dispositivo Master Flux per l'erogazione dei gas medicali al paziente.

TECNO-GAZ non risponde se i circuiti e le maschere sono utilizzati in modalità differenti da quello sopra indicato.

TECNO-GAZ non risponde di uso improprio di circuiti e mascherine.

Le mascherine sono vendute separatamente dal MASTER FLUX SOLO ED ESCLUSIVAMENTE COME RICAMBI DEL DISPOSITIVO.

2 CIRCUITI E MASCHERE

Components CICUIT

MF820ZMF	CIRCUITO COMPLETO	
MF835ZMF	MASCHERA misura 1	
MF836ZMF	MASCHERA misura 2	
MF837ZMF	MASCHERA misura 3	
MF838ZMF	MASCHERA misura 4	
SMFA197	CIRCUITO SCARICO PASSIVO	
MF824ZMF	CIRCUITO ASPIRAZIONE CENTRALIZZATA	

Il circuito **MF824ZMF** è composto da:

TERMINALE ASPIRAZIONE	
RIDUZIONE PER ASPIRA SALIVA	
VALVOLA UNIDIREZIONALE	

Il circuito **MF820ZMF** è composto da:

<p>RACCORDO DI CONNESSIONE ALLA SCATOLA FLUSSOMETRICA</p> <p>► Connettore 22 M/F 90°</p>	
<p>DUE TUBI DI LUNGHEZZA 1.8 MT (materiale PVC/PE)</p> <p>► Tubo trasparente e flessibile.</p> <p>► Tubo corrugato (spirale rigida) esternamente (anti-schiacciamento) liscio internamente per avere bassa compliance e rumorosità.</p> <p>► Connettori terminali flessibili per un facile adattamento.</p>	
<p>RACCORDO CONNESSIONE SCARICO (materiale: stirolox)</p> <p>► Riduzione 22-15</p>	
<p>RIDUZIONE CONNESSIONE SCARICO (materiale: TPE, PP)</p> <p>► Connettore elastomerico 9-11 mm</p>	

<p>CLIP SUPPORTO TUBI E FASCIA IN VELCRO</p> <p>► Consente di posizionare correttamente i tubi, la clip adesiva può essere fissata dietro la testiera oppure tramite l'apposita fascia in velcro può essere posizionata sulla testiera senza un fissaggio vincolante.</p> <p>► Permette un posizionamento fisso o con movimento rotatorio, in base alle esigenze.</p>	
---	---

La maschera è composta da:

<p>KIT RICAMBI SAGOMA NASALE E APPOGGIO FRONTALE Cod. 2ZMFA0050 misura 1 Cod. 2ZMFA0051 misura 2 Cod. 2ZMFA0052 misura 3 Cod. 2ZMFA0054 misura 4 (materiale: silicone) ► Consente di ridurre le emissioni di N₂O in ambiente ► Crea un posizionamento della maschera confortevole</p>	
<p>GUSCIO materiale: PC ► Trasparente</p>	
<p>SUPPORTO FRONTALE PICCOLO materiale: PC ► Trasparente Per maschere misura 1 e misura 2</p>	
<p>SUPPORTO FRONTALE GRANDE materiale: PC ► Trasparente Per maschere misura 3 e misura 4</p>	
<p>RACCORDO Y + Valvole PC + PC/silicone ► Permette il corretto flusso della miscela di gas impedendo che i gas esalati possano ritornare nel circuito di alimentazione ► La camera piccola riduce il rischio di permanenza di CO₂</p>	
<p>FASCIA NUCALE CON GANCI ► Permette di stabilizzare la maschera e regolare tramite le estremità in velcro la lunghezza per adattarla al paziente</p>	

ISTRUZIONI PER IL COLLEGAMENTO

Verificare l'integrità dei componenti prima di ogni trattamento.

Scegliere una maschera idonea al paziente (4 diverse misure per bambini e adulti).

Posizionare la maschera sul viso del paziente e regolare la fascia nucale. La maschera deve essere stabile e confortevole per il paziente. Collegare i tubi facendo attenzione alla freccia posta sul raccordo a Y. La freccia indica la direzione del flusso. Le valvole di non ritorno poste sul raccordo vincolano il flusso del gas nella direzione indicata dalla freccia.

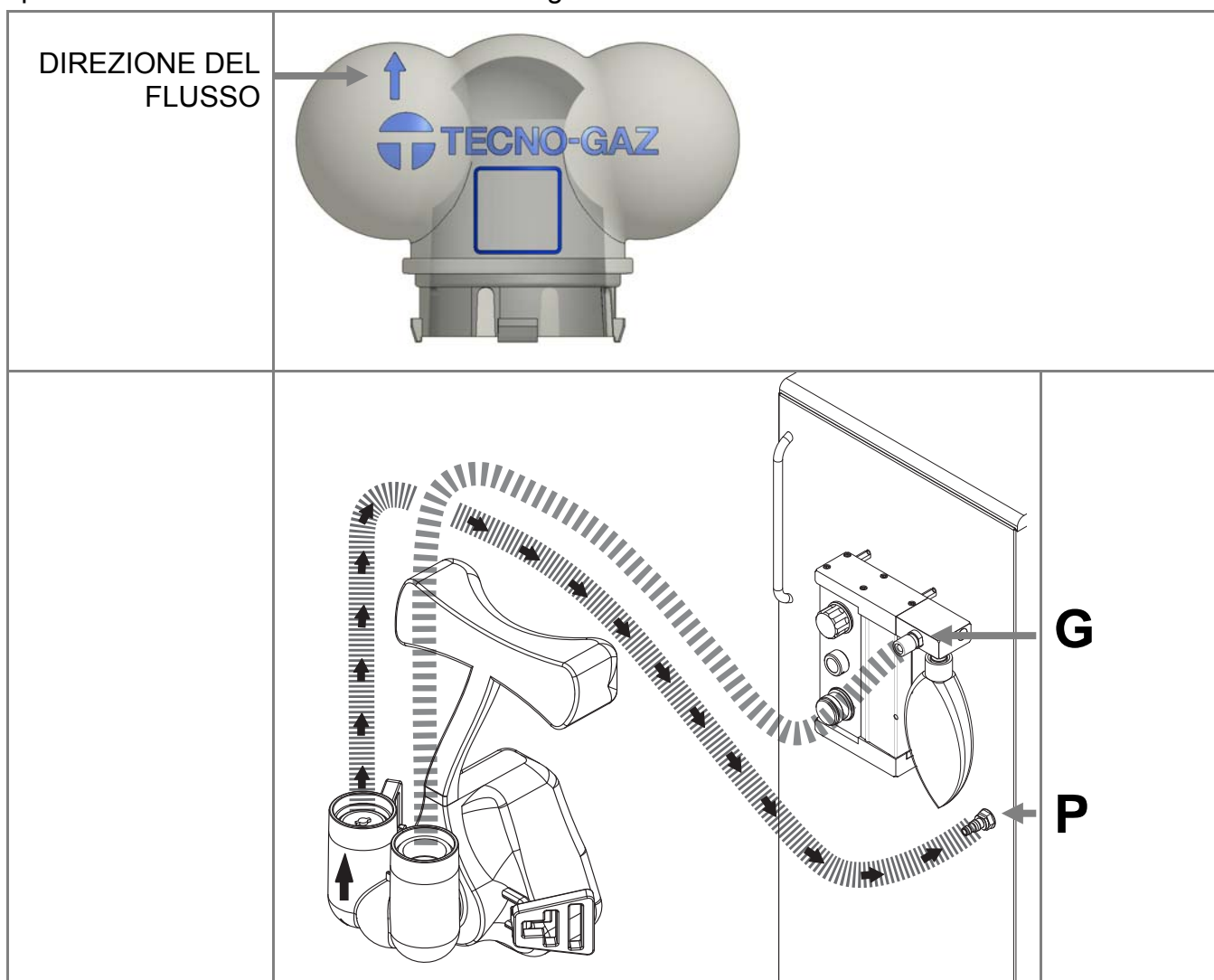

Tubo di entrata del gas: Collegare un tubo corrugato all'apposito portagomma (Punto G) sulla scatola flussometrica interponendo il raccordo connessione scatola flussometrica.

Collegare l'estremità libera al raccordo a Y posto sulla mascherina, LATO SENZA FRECCIA.

Tubo di scarico del gas: Collegare l'altro tubo corrugato all'apposito portagomma (Punto P) tramite il connettore elastomerico. Collegare l'estremità libera al raccordo a Y posto sulla mascherina, LATO CON FRECCIA.

Fissare la clip per stabilizzare i tubi dietro alla testiera della poltrona.

E' possibile un fissaggio tramite adesivo (fisso) o tramite l'apposito velcro in dotazione (mobile).

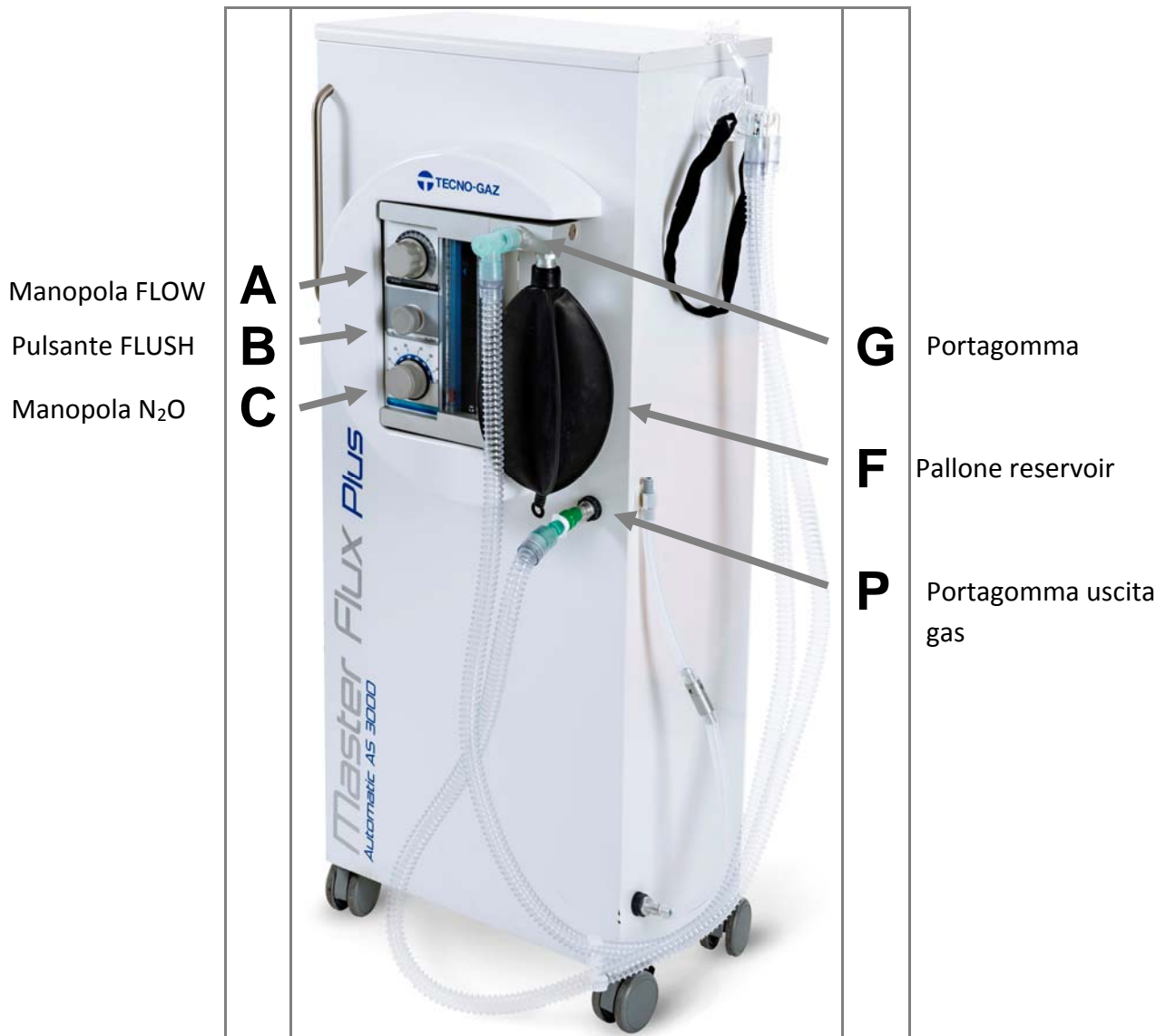
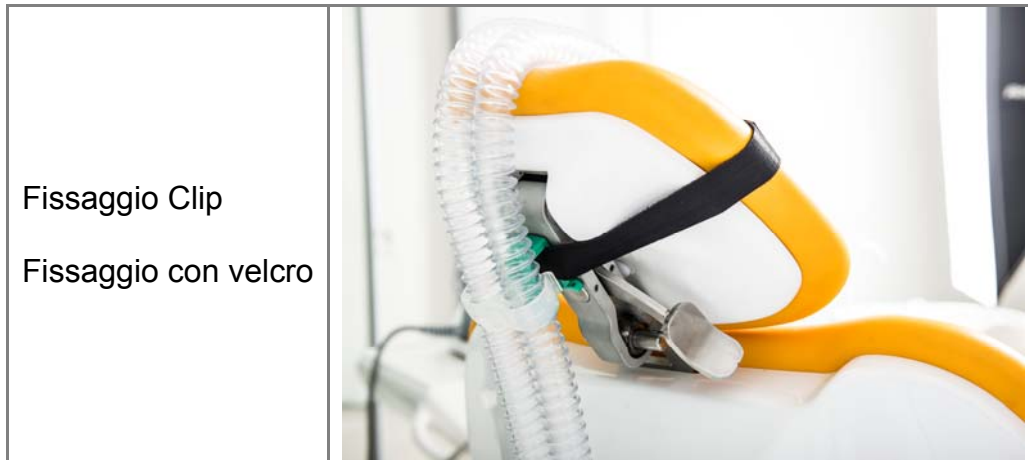

EVAQUAZIONE GAS ESALATI

L'operatore può scegliere la soluzione del trattamento dei gas esalati dal paziente utilizzando le seguenti connessioni:

SCARICO PASSIVO → ESTERNO STUDIO	
MASTER FLUX A MOBILE	MASTER FLUX A MURO
<p>Collegare il tubo, scarico gas del circuito maschera, al portagomma al centro del mobile.</p> <p>Collegare il circuito SMFA197, al portagomma nella parte inferiore sul mobile.</p> <p>Collocare all'esterno dello studio, l'estremità del tubo spiralato, e verificare la presenza del filtro finale.</p> <p>Lo scarico deve avvenire in luogo aperto e ben ventilato.</p>	<p>Collegare il tubo scarico gas del circuito all'apposito portagomma (SMFA257), successivamente al tubo spiralato (SMFA197).</p> <p>Collocare all'esterno l'estremità del tubo spiralato e verificare la presenza del filtro finale.</p> <p>Lo scarico deve avvenire in luogo aperto e ben ventilato.</p>
	

SCARICO ATTIVO → ASPIRATORE CHIRURGICO

MASTER FLUX A MOBILE

Collegare il tubo, scarico gas del circuito maschera, al portagomma al centro del mobile.

Collegare il circuito MF824ZMF al portagomma sul mobile.

Collegare il terminale all'aspiratore.

MASTER FLUX A MURO

Collegare il circuito MF824ZMF al circuito di scarico.
Collegare il terminale all'aspiratore.



ASPIRAZIONE
MF824ZMF

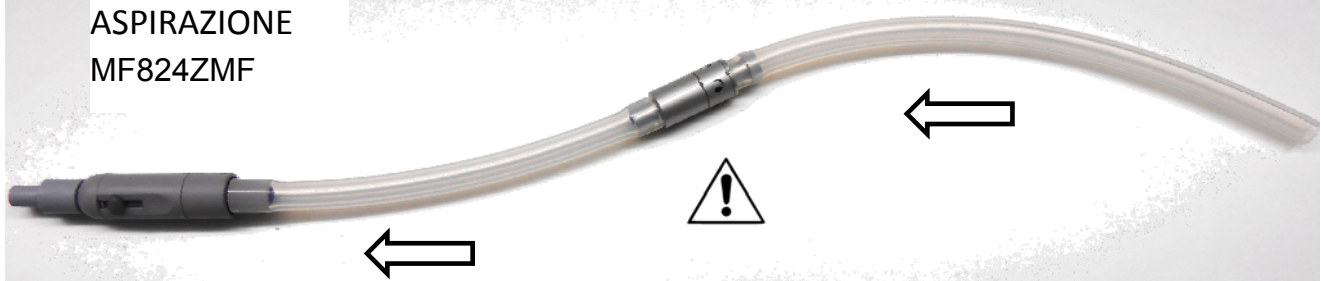

REGOLAZIONE DELLA VALVOLA

Ruotare la ghiera forata della valvola (SMFA236) fino alla chiusura dei fori.

Avviare l'erogazione dell' OSSIGENO impostando ~10 NI/min.

Avviare l'aspiratore chirurgico, impostare il valore minimo di aspirazione.

Osservare LA SACCA ANESTESIA.

Ruotare la ghiera forata della valvola aprendo progressivamente i fori fino ad ottenere lo stato ideale della sacca anestesia "MEZZO PIENO MEZZO VUOTO".

ATTENZIONE:

Variando i FLUSSI erogati, può essere necessario, regolare i corretti flussi di aspirazione dei gas esalati.



4 PULIZIA**NON utilizzare detergenti aggressivi per la pulizia della plastica**

Pulire le superfici del dispositivo con panno asciutto.

Prima e dopo utilizzo pulire, detergere o sterilizzare i particolari a contatto con il paziente o con il suo respiro.

Tabella della pulizia dei componenti MASTER FLUX

CODICE	DESCRIZIONE	MATERIALE	STERILIZZAZIONE	DISINFEZIONE
			VAPORE	SALI QUATERNARI
CM84001	SACCA ANESTESIA	GOMMA (NO LATEX FREE)	NO	SI
MF820ZMF	CIRCUITO	PVC	NO	NO
	MASCHERA	PC+SILICON	T134	SI
	FASCIA NUCALE	VELCRO	NO	NO
SMFA236	VALVOLA ELIMINAZIONE GAS	AL + SILICON	T134	SI
SMFA197	CIRCUITO SCARICO	PVC + AL	NO	NO

ASSEMBLAGGIO MASCHERA

Dopo la pulizia del dispositivo, assemblare la maschera.

**ATTENZIONE ALLA DIREZIONE DEI FLUSSI
SONO PRESENTI VALVOLE UNIDIREZIONALI
CHE VINCOLANO IL FLUSSO NELLA DIREZIONE INDICATA**

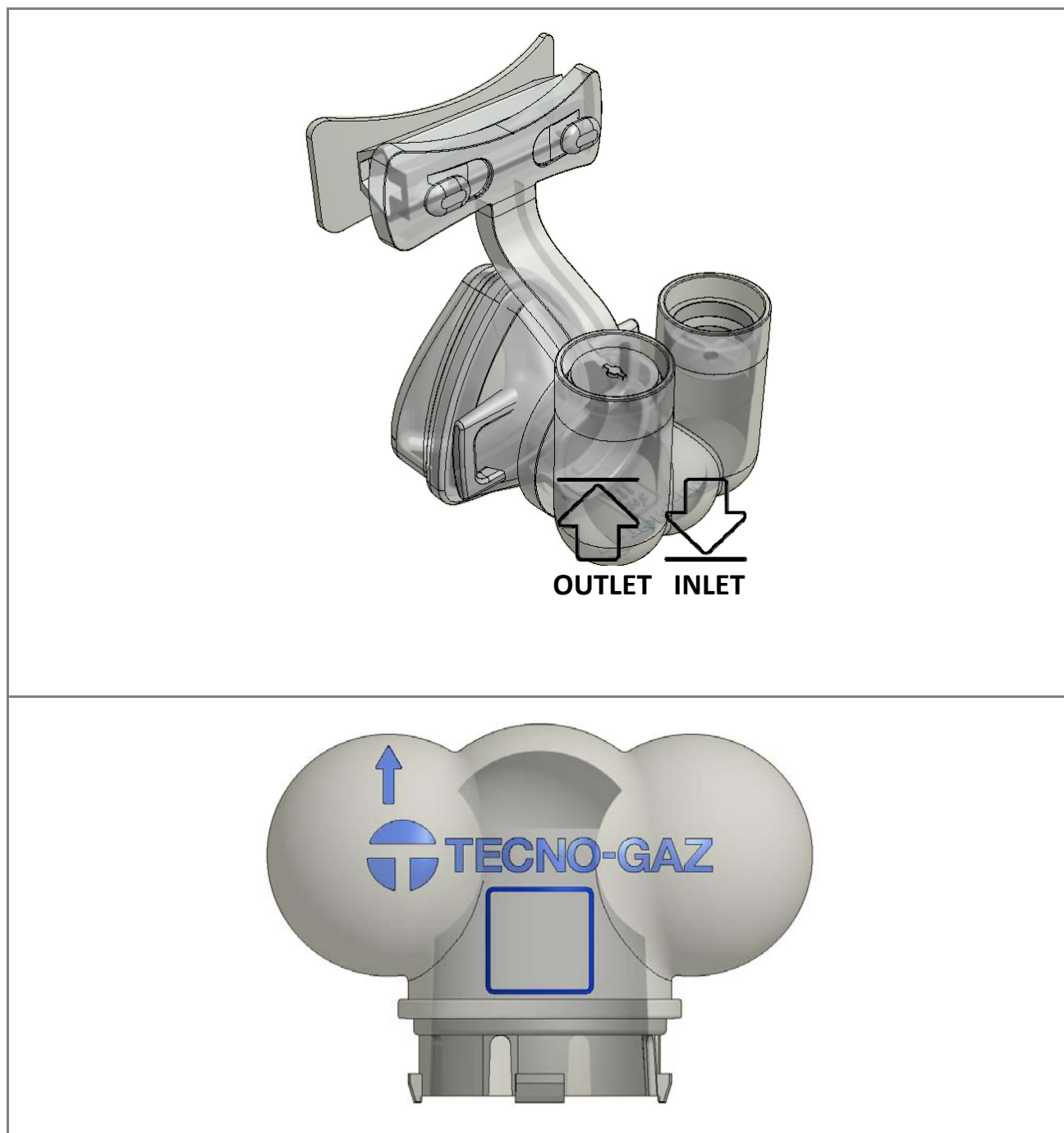

Circuito INGRESSO



INLET



Circuito SCARICO

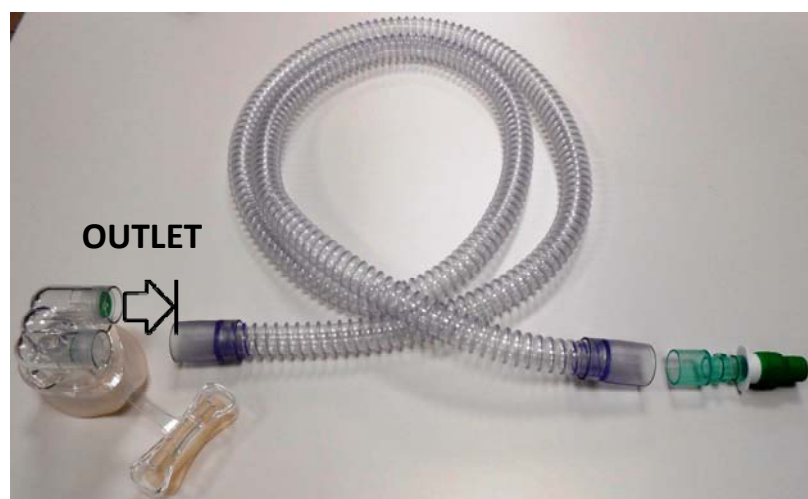

OUTLET



Identificazione circuito gas esalati



Per facilitare l'identificazione del circuito di scarico durante il montaggio circuito-mascherina vengono forniti due anelli blu (cod. 1ZMFA0082)

Le figure A B C D mostrano come utilizzare gli anelli.

L'indicatore è sterilizzabile in autoclave.



TABLE OF CONTENTS

1. INTENDED USE
3. CONNECTION
4. CLEANING

1 INTENDED USE

The Tecno-gaz circuits and masks are accessories of device Master Flux and should only be used with the device Master Flux for the supply of medical gases to the patient.

TECNO-GAZ is not responsible if the circuits and masks are used in a manner different from that stated above.

TECNO-GAZ is not liable for misuse of circuits and masks.



The masks are sold separately from the MASTER FLUX ONLY AS PARTS OF THE DEVICE.

2 | **CIRCUIT AND MASK**





Components CICUIT

<p>MF820ZMF</p>	<p>CIRCUIT COMPLETE</p>	
<p>MF835ZMF</p>	<p>MASK size 1</p>	
<p>MF836ZMF</p>	<p>MASK size 2</p>	
<p>MF837ZMF</p>	<p>MASK size 3</p>	
<p>MF838ZMF</p>	<p>MASK size 4</p>	
<p>SMFA197</p>	<p>CIRCUIT EXHAUST PASSIVE</p>	
<p>MF824ZMF</p>	<p>CIRCUIT CONNECTION OF ASPIRATOR</p>	

The circuit **MF824ZMF** is composed of:







<p>TERMINAL ASPIRATION</p>	
<p>REDUCTION FOR SUCTION SALIVA</p>	
<p>ONE-WAY VALVE</p>	

the circuit **MF820ZMF** is composed of:

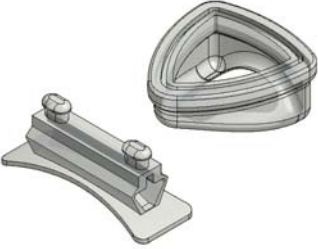
<p>Fitting connection to flowmeter box ▶ Connection 22 M/F 90°</p>	
<p>Two tubes length 1.8 m (material PVC/PE) ▶ Transparent and flexible tube. ▶ Corrugated tube (rigid spiral) externally (anti-crushing) smooth inside for low compliance and noise. ▶ Flexible connectors for easy insertion.</p>	
<p>Exhaust fitting connection (material: stirolox) ▶ Reduction 22-15</p>	
<p>Reducing exhaust connection (material: TPE, PP) ▶ Elastomeric connector 9-11 mm</p>	

<p>Pipe clip support and velcro band ▶ Allows correct positioning of the tubes, the adhesive clip can be secured behind the headboard or via the Velcro strip can be positioned on the headboard without a secure fixing. ▶ It allows a positioning with fixed or rotary movement, according to the needs.</p>	
--	---

The mask is composed of:

<p>Kit Silhouette nasal and Support front Code 2ZMFA0050 size 1 Code 2ZMFA0051 size 2 Code 2ZMFA0052 size 3 Code 2ZMFA0054 size 4 (material: silicon) ▶ It reduces N2O environment emissions ▶ Create a mask placement comfortable</p>	
<p>Shell (material: PC) ▶ Transparent</p>	
<p>Small support front (material: PC) ▶ Transparent For mask size 1 and size 2</p>	
<p>Large support front (material: PC) ▶ Transparent For mask size 3 and size 4</p>	
<p>Fitting Y (PC) with valves (PC/silicone) ▶ Allows the correct flow of the gas mixture by preventing the exhaled gas can flow back into the supply circuit. ▶ The small room eliminates the risk of permanence CO2</p>	
<p>HEAD RIBBON WITH FASTENER FOR HEAD RIBBON ▶ The mask stabilizing and regulating via a velcro the length to adapt it to the patient.</p>	

CONNECTION INSTRUCTIONS

Check the integrity of the components.

Choose the most suitable mask for the patient.

Place the mask and adjust the head ribbon. The mask must be stable and comfortable for the patient. Connect the pipes, paying attention to the arrow on the Y fitting. The arrow indicates the flow direction. The non-return valves, placed in the fitting, push the gas flow in the direction indicated by the arrow.

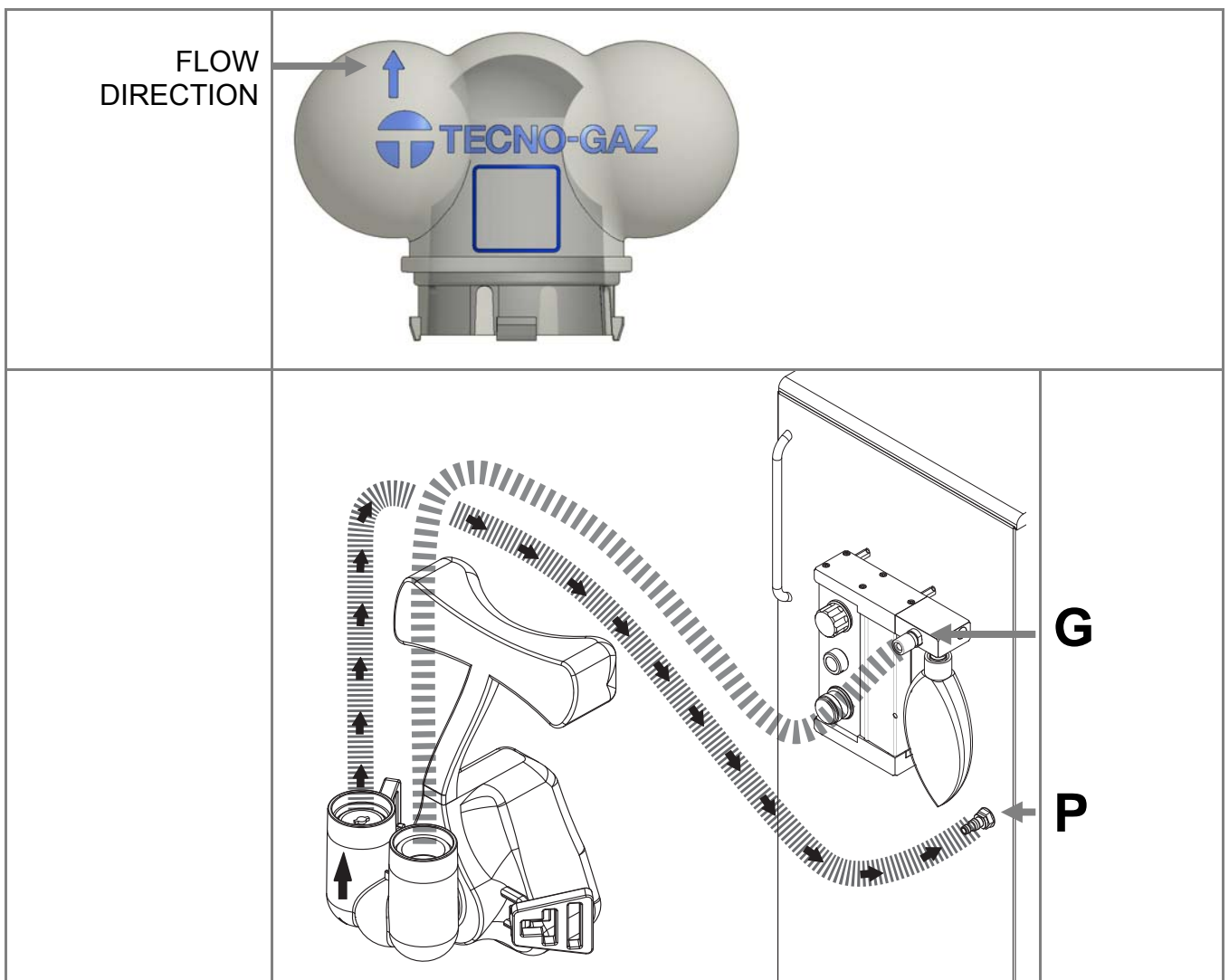

Gas inlet pipe: Connect a hose to the special corrugated tube (Item G) to the flow control box by inserting the connector connection flow control box ".

Connect the free end to the Y connector placed on the mask, WITHOUT SIDE ARROW.

Gas inlet pipe: Connect the other corrugated pipe to the appropriate hose (Pos P) through the elastomeric connector. Connect the free end to the Y connector placed on the mask, SIDE WITH ARROW.

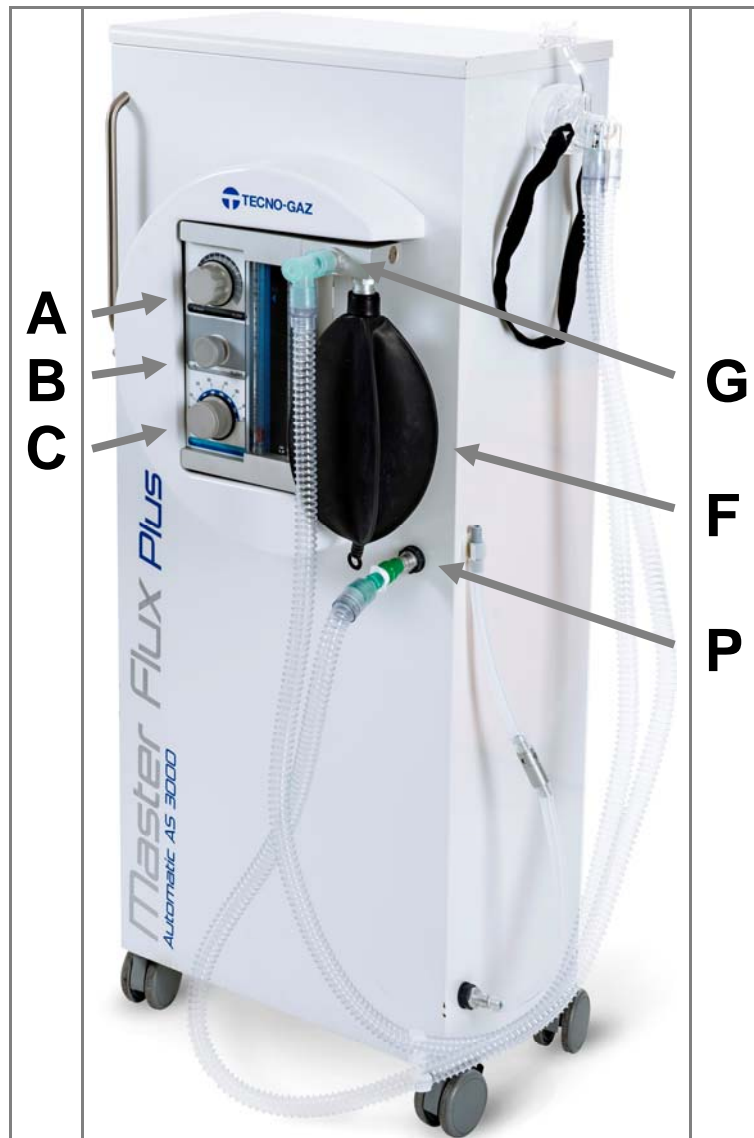
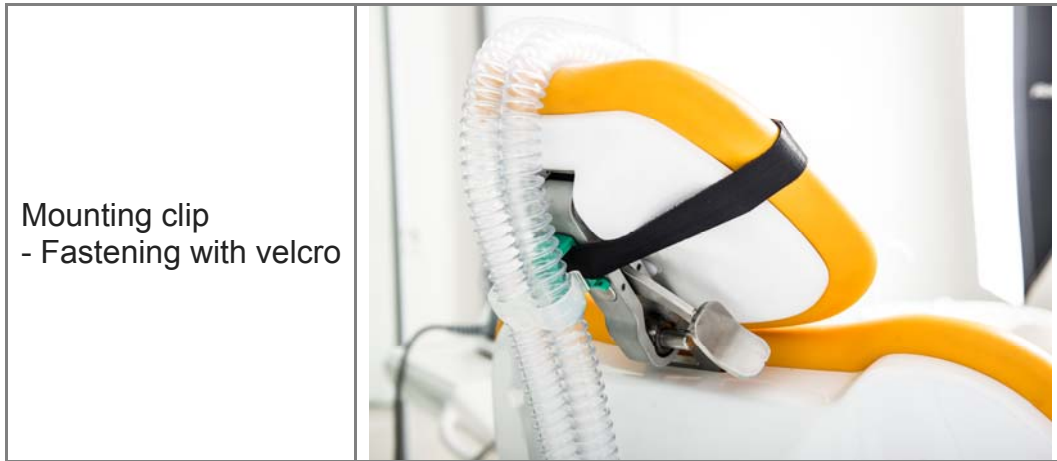

Fix the clip to stabilize the pipes behind the headboard of the chair.

And 'possible fixing with adhesive (fixed) or through the appropriate supplied Velcro (detachable).



EVACUATION EXHALED GASES

The operator can choose the best solution for processing the exhaled gases, using the following connections:

PASSIVE EXHAUST	
UNIT-MOUNTED MASTER FLUX	WALL-MOUNTED MASTER FLUX
<p>Connect the hose, exhaust gas circuit mask to the hose in the center at the center of the unit.</p> <p>Connect the circuit SMA197, to the hose connection at the bottom of the cabinet.</p> <p>Connect the end of the spiral tube to the outside and make sure there is a final filter.</p> <p>The discharge must take place in an open, well-ventilated.</p>	<p>Connect the exhaust gas pipe of the appropriate circuit hose (SMFA257) after the spiral tube (SMFA197).</p> <p>Connect the end of the spiral tube to the outside and make sure there is a final filter.</p> <p>The discharge must take place in an open, well-ventilated.</p>
	

ACTIVE EXHAUST

UNIT-MOUNTED MASTER FLUX

Connect the hose, exhaust gas circuit mask to the hose in the center of the cabinet.
 Connect the circuit MF824ZMF to the hose on mobile.
 Connect the terminal to the suction.

WALL-MOUNTED MASTER FLUX

MF824ZMF connect the circuit to the discharge circuit.
 Connect the terminal to the suction.

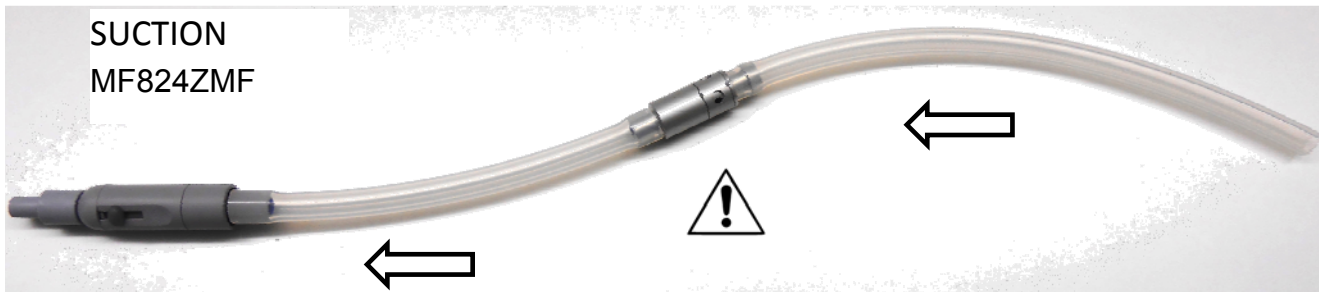

SETTING THE VALVE

Turn the ring perforated valve (SMFA236) until closing holes.
 Start dispensing OXYGEN setting ~ 10 NI / min.
 Start the surgical aspirator, set the minimum intake.
 Observe THE BAG ANESTHESIA.
 Turn the ring perforated valve gradually opening the holes until you get the ideal state of the BAG ANESTHESIA "HALF FULL HALF EMPTY".

CAUTION:

By varying FLOW, it may be necessary, adjust the correct intake flows of exhaled gases.



4 CLEANING**Use detergents that are not aggressive to plastic**

Clean the surfaces of the device with a dry cloth.

Before and after use, clean, clean or sterilize the parts in contact with the patient or with his breath.

Cleaning table for MASTER FLUX parts

			STERILISATION	DISINFECTION
CODE	DESCRIPTION	MATERIAL	STEAM	QUATERNARY SALTS
CM84001	BAG ANESTHESIA	RUBBER (NO LATEX FREE)	NO	SI
MF820ZMF	CIRCUIT	PVC	NO	NO
	MASK	PC+SILICON	T134	SI
	HEAD RIBBON	VELCRO	NO	NO
SMFA236	ONE-WAY VALVE	AL + SILICON	T134	SI
SMFA197	INTAKE	PVC + AL	NO	NO

MASK ASSEMBLY

After cleaning the device, assemble the mask according to the diagram below.

**ATTENTION TO THE DIRECTION OF FLOW
ARE THESE VALVES
BINDING THE FLOW IN THE DIRECTION SHOWN**



Circuit INLET



INLET



Circuit OUTLET



OUTLET



Exhaled Gas Circuit identification



For easy identification of discharge circuit, during are provided template-circuit, assembly, two blue rings (Cod. 1ZMFA0082).

Figures A B C D show how to use the rings. The indicator is autoclavable.



INHALTSVERZEICHNIS

1. BESTIMMUNGSGEMÄSSER GEBRAUCH:
3. ANSCHLÜSSE
4. REINIGUNG

1 BESTIMMUNGSGEMÄSSER GEBRAUCH:

Der Schlauch und die Masken Tecno-Gaz sind Zubehörteile der Vorrichtung Master Flux und müssen ausschließlich mit der Vorrichtung Master Flux für die Abgabe der medizinischen Gase an den Patienten verwendet werden.

TECNO-GAZ haftet nicht, wenn Schlauch und Masken auf andere Weise benutzt werden.

TECNO-GAZ haftet nicht bei unsachgemäßem Gebrauch vom Schlauch und Masken.



Die Masken werden vom MASTER FLUX getrennt, NUR ALS ERSATZTEILE DER VORRICHTUNG

2 SCHLAUCH UND MASKEN





Bestandteile:

MF820ZMF	SCHLAUCH	
MF835ZMF	Maskengröße 1	
MF836ZMF	Maskengröße 2	
MF837ZMF	Maskengröße 3	
MF838ZMF	Maskengröße 4	
MF824ZMF	ZENTRALISIERTER ABSAUGSCLAUCH	

ABSAUGUNG (cod.MF824ZMF)

ABSAUGANSCHLUSS	
REDUZIERUNG FÜR SPEICHELABSAUGUNG	
EINWEGVENTIL	

Der Schlauch Ref-Nr. **MF820ZMF** besteht aus

<p>Verbindungsanschluss Flussmeterbox</p> <ul style="list-style-type: none"> ▶ Steckverbinder 22 M/F 90° 	
<p>Zwei Schläuche mit 1.8 m Länge (Material PVC/PE)</p> <ul style="list-style-type: none"> ▶ Durchsichtiger und biegsamer Schlauch ▶ Welliger Schlauch (starre Spirale) extern (Quetschungsschutz), innen glatt, für niedrige Compliance und Lärm. ▶ Biegsame Steckverbinder für eine einfache Anpassung 	
<p>Anschluss Ablaufgarnitur (Material: Stirolox)</p> <ul style="list-style-type: none"> ▶ Reduzierung 22-15 	
<p>Reduzierung Ablaufgarnitur (Material: TPE, PP)</p> <ul style="list-style-type: none"> ▶ Elastomerischer Steckverbinder 9-11 mm 	

<p>Schlauchträgerklammer und Klettverschlussband</p> <ul style="list-style-type: none"> ▶ Erlaubt die korrekte Positionierung der Schläuche; der Klebeclip kann hinter dem Kopfstück befestigt oder über ein entsprechendes Klettverschlussband auf dem Kopfstück ohne eine festen Befestigung positioniert werden. ▶ Erlaubt eine feste Positionierung, oder mit Drehbewegung, je nach Bedarf. 	
---	---

Die Maske besteht aus:

<p>Silikonmaskenpolster und Silikonstirnpolster Code 2ZMFA0050 Größe 1 Code 2ZMFA0051 Größe 2 Code 2ZMFA0052 Größe 3 Code 2ZMFA0054 Größe 4 (Material: Silikon) ► Erlaubt die Reduzierung der N₂O-Abgaben in die Umgebung ► Erlaubt eine bequeme Positionierung der Maske</p>	
<p>Schale (aus PC) ► Durchsichtig</p>	
<p>Klein frontal-Halter (aus PC) ► Durchsichtig Zur Maske Größe 1 und Größe 2</p>	
<p>Groß frontal-Halter (aus PC) ► Durchsichtig Zur Maske Größe 3 und Größe 4</p>	
<p>Y-Anschluss (PC) mit Ventilen (PC/Silikon) ► Erlaubt den korrekten Fluss der Gasmischung, wodurch verhindert wird, dass die ausgeatmeten Gase in den Versorgungskreislauf zurückkehren. ► Die kleine Kammer eliminiert die Gefahr der CO₂-Permanenz.</p>	
<p>KOPFBAND MIT HACKEN ► Erlaubt die Stabilisierung der Maske und Einstellung der für den Patienten angemessenen Länge dank des Klettverschlusses.</p>	

ANSCHLUSSANWEISUNGEN

Prüfen Sie, dass alle Bestandteile i. O. sind

Wählen Sie die geeignete Maske für den Patient.

Lassen Sie dem Patient die Maske anziehen, und stellen Sie das Kopfband ein. Die Maske muss fest und für den Patienten angenehm sein.

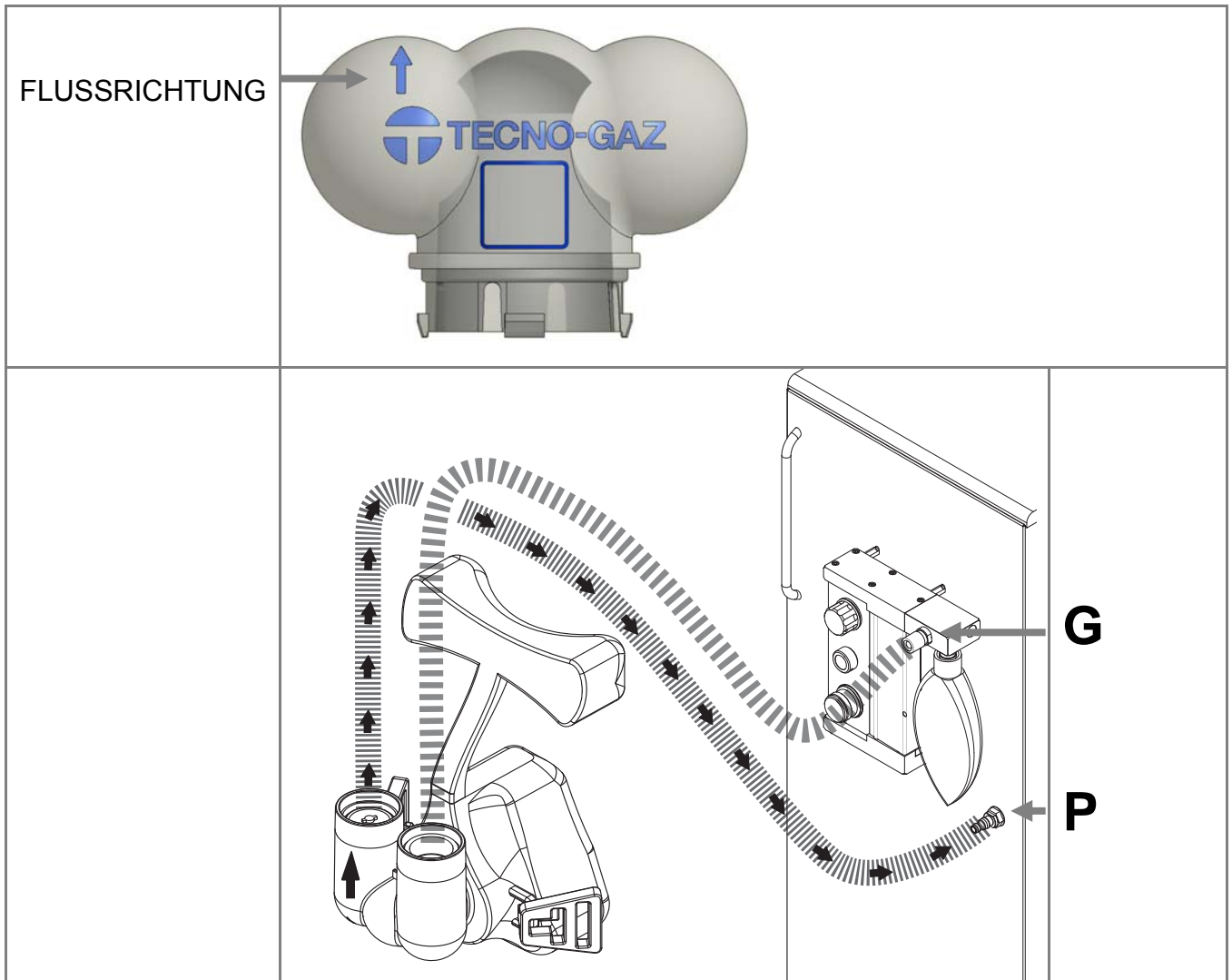

Eingangsschlauch: Verbinden Sie den Schlauch mit Verbindungs-Pos. G im Steuereinheit.

Verbinden Sie den freien Teil mit Y Verbindung im Maske – TEIL OHNE ZEIGER

Ausgangsschlauch: Verbinden Sie den zweiten Schlauch mit Verbindungs-Pos. P durch elastometrischer Verbindung

Verbinden Sie den freien Teil mit Y Verbindung im Maske – TEIL MIT ZEIGER



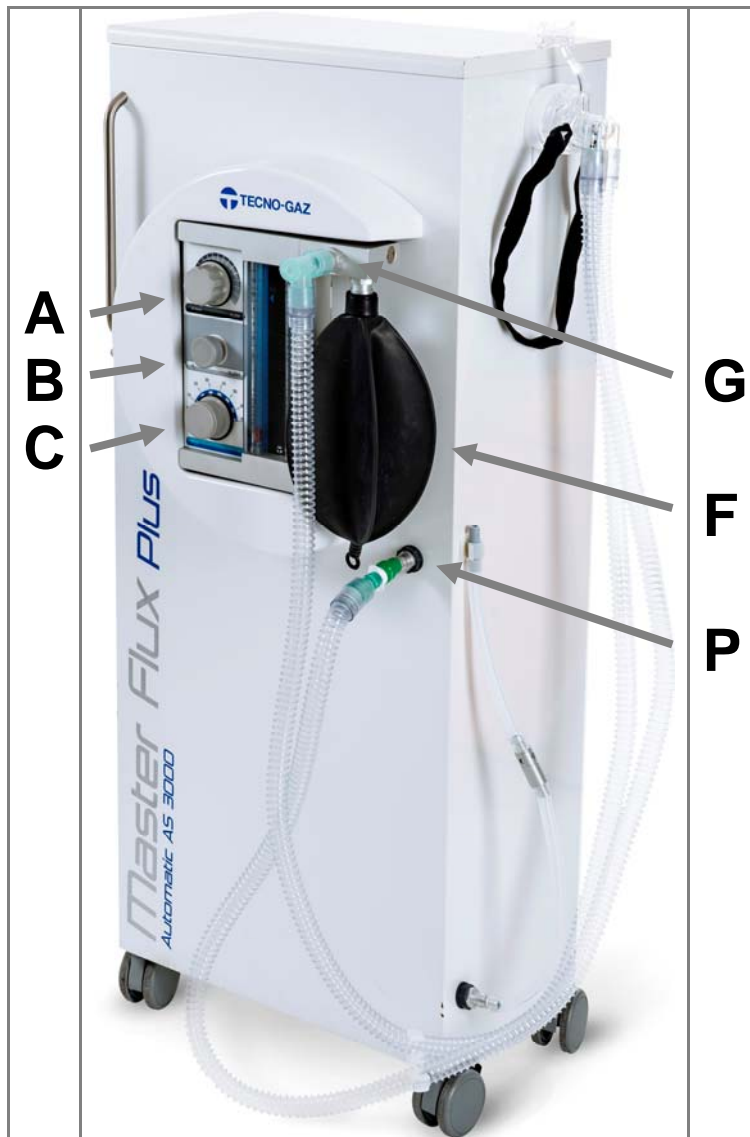

Machen Sie die Klammer fest, um den Schlauch hinter den Kopfhalter vom Behandlungseinheit festzumachen.

Man kann das mit einem Kleber oder mit dem zusammengeliefert Klettband festmachen.

Klammerbefestigung
- Befestigung durch Klettband



ENTLEERUNG von aufgestiegene Gasen

AKTIVE FREISETZUNG	
MASTER FLUX in der bewegbaren Ausführung	MASTER FLUX in der Wandausführung
<p>Anschluss an die chirurgische Absaugvorrichtung Den Kreis MF824ZMF entfernen. Den Kreis an die chirurgische Absaugvorrichtung anschließen.</p>	<p>Verbinden Sie den Schlauch MF824ZMF mit Entleerungseinheit. Verbinden Sie den Absauganschluß</p>
	
<div style="display: flex; align-items: center;"> <div style="border: 1px solid black; padding: 2px; margin-right: 10px;"> ABSAUGUNG MF824ZMF </div>  </div>	
<p>VNETILEINSTELLUNG</p> <p>Den gelochten Schraubring des Ventils (SMFA236) so drehen, dass die Löcher geschlossen werden.</p> <p>Die Abgabe des SAUERSTOFFS durch Eingabe von ~10 NI/min. starten.</p> <p>Die chirurgische Absaugvorrichtung starten, dabei die minimale Saugstärke einstellen.</p> <p>Den NARKOSEBEUTEL beobachten.</p> <p>Den gelochten Schraubring des Ventils drehen, um die Löcher allmählich zu öffnen, bis der Narkosebeutel den Idealzustand „HALB VOLL – HALB LEER“ erreicht hat.</p> <p>ACHTUNG:</p> <p>Bei Veränderung der Abgabe-FLÜSSE könnte eine Neueinstellung der korrekten Absaugflüsse der ausgeatmeten</p>	

Gase notwendig sein.

4 REINIGUNG



Für die Plastikteile keine aggressiven Reinigungsmittel verwenden.

Die Gerätoberfläche mit einem trockenen Tuch reinigen.

Vor und nach dem Gebrauch alle Teile, die mit dem Patienten oder seinem Atem in Berührung kommen, reinigen oder sterilisieren.

Tabelle zur Reinigung der MASTER FLUX Bestandteile

			STERILISATION	DESINFEKTION
ART.-NR.	BESCHREIBUNG	MATERIAL	DAMPF	QUATERNÄRE SALZE
CM84001	NARKOSEBEUTEL	GUMMI (NEIN LATEX FREE)	NEIN	JA
MF820ZMF	SCHLAUCH	PVC	NEIN	NEIN
	MASKEN	PC+SILIKON	T134	JA
	KOPFBAND	KLETTBAND	NEIN	NEIN
SMFA236	VENTIL für Gasentfernung	AL + SILICON	T134	JA
SMFA197	Entleerungsschlauch	PVC + AL	NEIN	NEIN

Maskenzusammenbau

Nach der Vorrichtungreinigung die Maske zusammenbauen.

DIE FLUSSRICHTUNG BEACHTEN

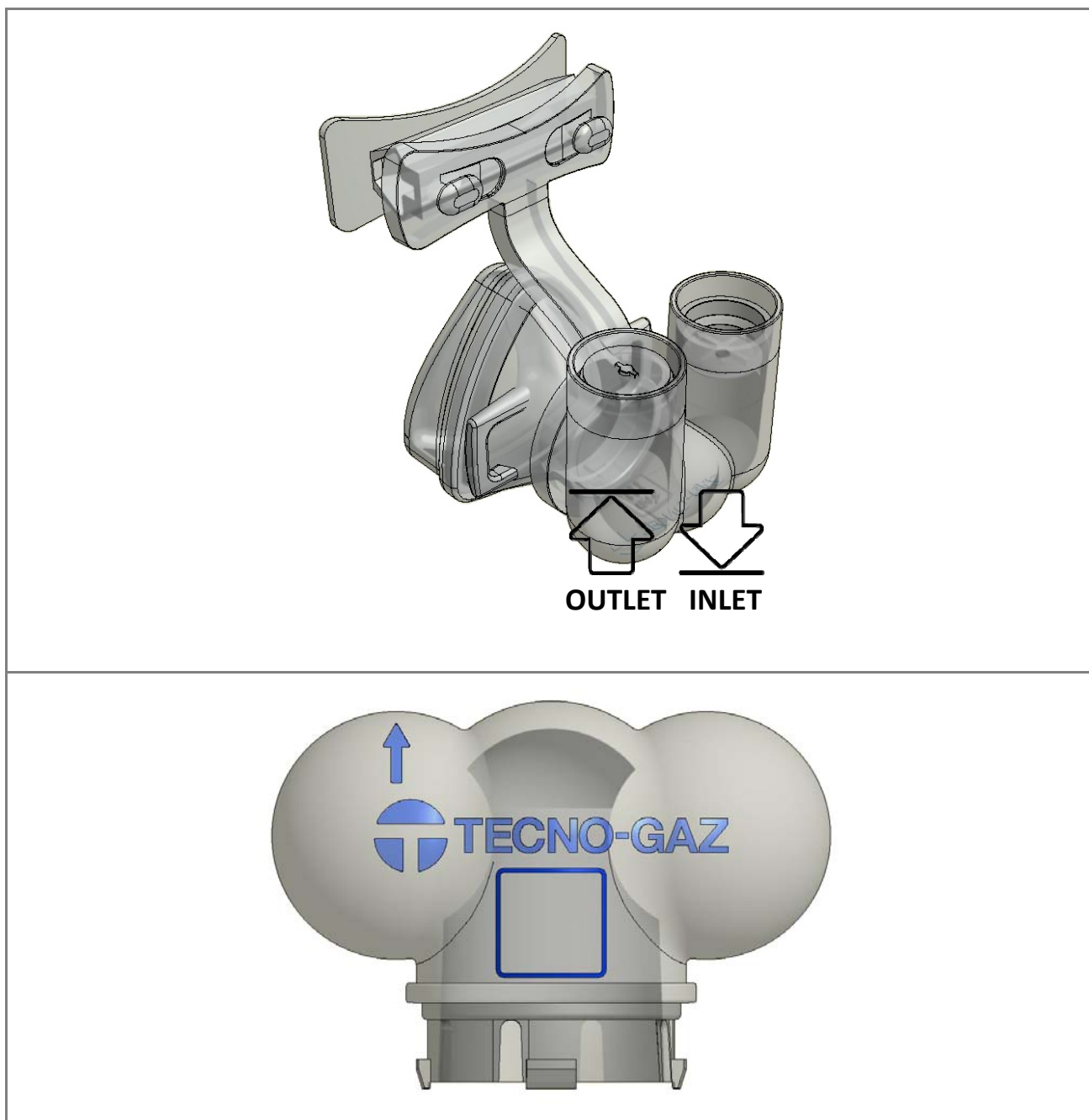

Eingangsumkreis



INLET



Ausgangsumkreis

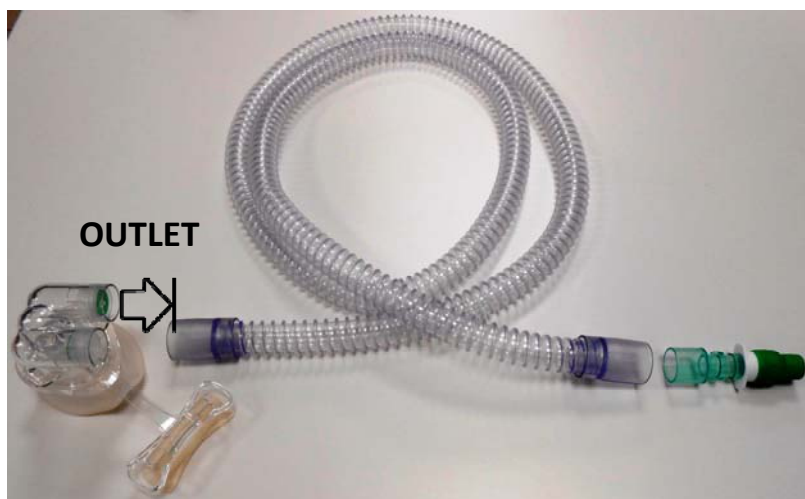

OUTLET



Gaskreisidentifizierung ausgeatmet



2 blaue Ringe werden mitgeliefert, um schlauch und MasKenz identifizieren (Ref. 1ZMFA0082)

Die Figuren A B C D zeigen wie die Ringe zu verwenden. Der ringe sind sterilisierbar.



ÍNDICE

1. USO PREVISTO
3. CONEXIONES
4. LIMPIEZA

1 USO PREVISTO

Los circuitos y las mascarillas Tecno-gaz son accesorios del dispositivo Master Flux; deben ser utilizados exclusivamente con el dispositivo Master Flux para suministrar gases medicinales al paciente.

TECNO-GAZ no responde si los circuitos y las mascarillas se utilizan de manera diferente de la indicada anteriormente.

TECNO-GAZ no responde por el uso inadecuado de circuitos y mascarillas.

Las mascarillas se venden por separado del MASTER FLUX, ÚNICA Y EXCLUSIVAMENTE COMO REPUESTOS DEL DISPOSITIVO.

2 CIRCUITOS Y MASCARILLAS



Componentes CICUITO :

MF820ZMF	CIRCUITO COMPLETO	
MF835ZMF	MASCHERA tamaño 1	
MF836ZMF	MASCHERA tamaño 2	
MF837ZMF	MASCHERA tamaño 3	
MF838ZMF	MASCHERA tamaño 4	
SMFA197	CIRCUITO SCARICO PASSIVO	
MF824ZMF	CIRCUITO DE ASPIRACIÓN CENTRALIZADA	

Il circuito **MF824ZMF** è composto da:

<p>TERMINAL DE ASPIRACIÓN</p>	
<p>REDUCCIÓN PARA ASPIRADOR-SALIVA</p>	
<p>VÁLVULA UNIDIRECCIONAL</p>	

El circuito **MF820ZMF** está compuesto por:

<p>Empalme de conexión caja fluxométrica</p> <ul style="list-style-type: none"> ▶ Conector 22 M/F 90° 	
<p>Dos tubos de 1.8 m de largo (material PVC/PE)</p> <ul style="list-style-type: none"> ▶ Tubo transparente y flexible. ▶ Tubo corrugado (espiral rígida) externamente (antiaplastamiento), liso internamente para tener baja distensibilidad y rumorosidad. ▶ Conectores terminales flexibles para una fácil adaptación. 	
<p>Empalme de conexión descarga (material: stirolux)</p> <ul style="list-style-type: none"> ▶ Reducción 22-15 	
<p>Reducción conexión descarga (material: TPE, PP)</p> <ul style="list-style-type: none"> ▶ Conector elastomérico 9-11 mm 	

<p>Sujetador soporte de tubos y banda de velcro</p> <ul style="list-style-type: none"> ▶ Permite ubicar correctamente los tubos, el sujetador adhesivo puede fijarse detrás del cabezal o mediante la respectiva banda de velcro puede ubicarse en el cabezal sin una fijación vinculante. ▶ Permite una ubicación fija o con movimiento giratorio, en base a las exigencias. 	
---	---

La mascarilla está compuesta por:

<p>Kit Silueta nasal Apoyo frente Cód. 2ZMFA0050 tamaño 1 Cód. 2ZMFA0051 tamaño 2 Cód. 2ZMFA0052 tamaño 3 Cód. 2ZMFA0054 tamaño 4 (material: silicona) ▶ Permite reducir las emisiones de N₂O en el ambiente ▶ Permite un cómodo posicionamiento de la mascarilla</p>	
<p>Exterior (material: PC) ▶ Transparente</p>	
<p>Apoyo frente pequeño (material: PC) ▶ Transparente Para el tamaño 1 y el tamaño 2</p>	
<p>Apoyo frente grande (material: PC) ▶ Transparente Para el tamaño de 3 y el tamaño 4</p>	
<p>Empalme en Y (PC) con Válvulas (PC/silicona) ▶ Permite el flujo correcto de la mezcla de gases e impide que los gases exhalados puedan volver al circuito de alimentación ▶ La cámara pequeña elimina el riesgo de permanencia de CO₂</p>	
<p>GANCHO PARA LA BANDA NUCAL ▶ Permite estabilizar la mascarilla y regular mediante los extremos de velcro la longitud para adaptarla al paciente.</p>	

INSTRUCCIONES PARA LA CONEXIÓN

Verifique la integridad de los componentes.

Escoja una mascarilla adecuada para el paciente.

Ubique la mascarilla y regule la banda nucal. La mascarilla debe tener estabilidad y resultar cómoda para el paciente. Conecte los tubos prestando atención a la flecha ubicada en el empalme en Y. La flecha indica la dirección del flujo. Las válvulas de no retorno ubicadas en el empalme dirigen el flujo del gas en la dirección indicada por la flecha.

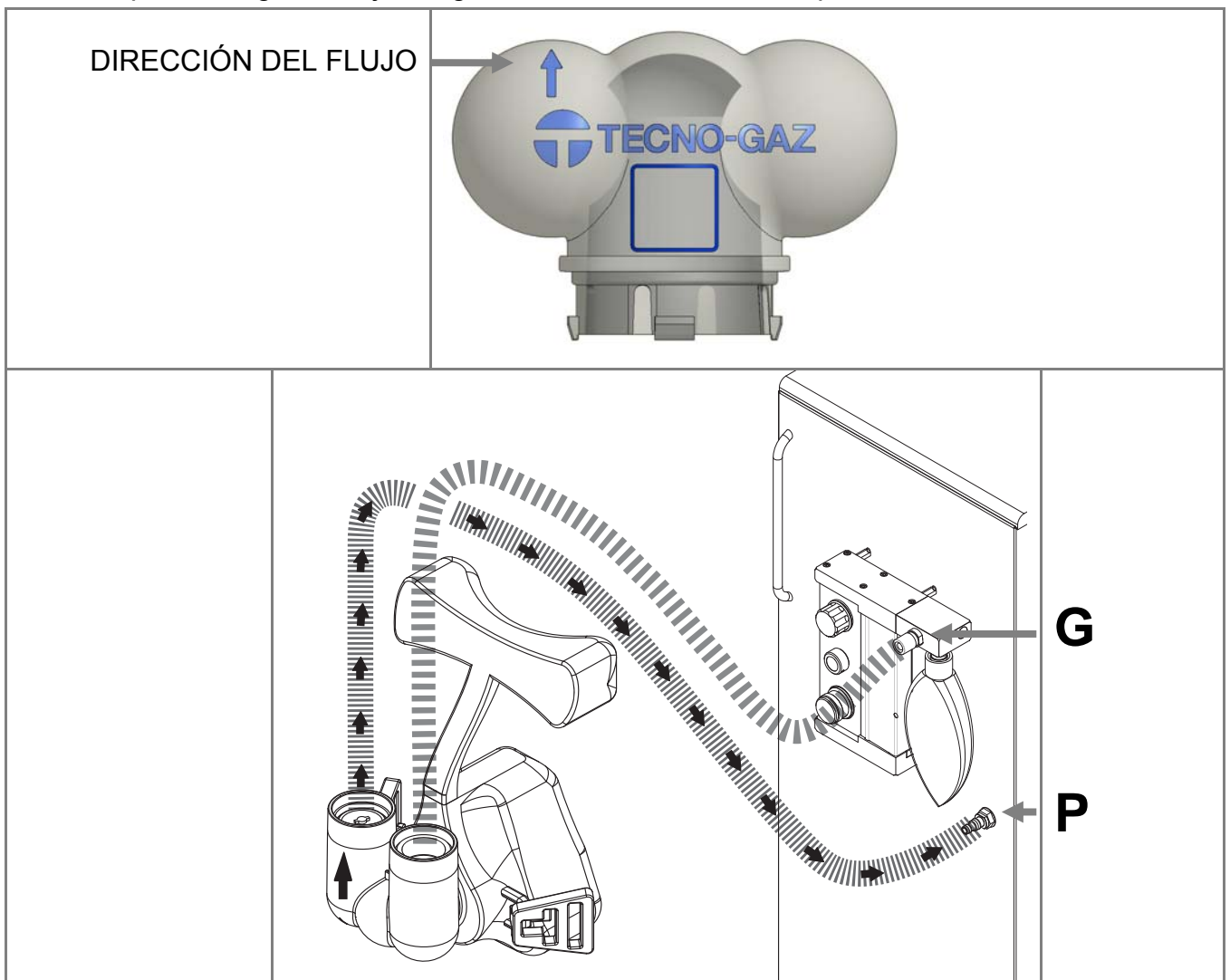

Tubo ingreso gas: Conecte el empalme libre a 90° del tubo de alimentación a la respectiva boquilla (Pos. G) de la unidad de suministro.

Descargador de gas: Conecte el extremo libre mediante el conector elastomérico a la boquilla presente en el mueble.

Fije el sujetador para estabilizar los tubos detrás del cabezal del sillón. Es posible una fijación mediante adhesivo (fija) o mediante el velcro suministrado (móvil).

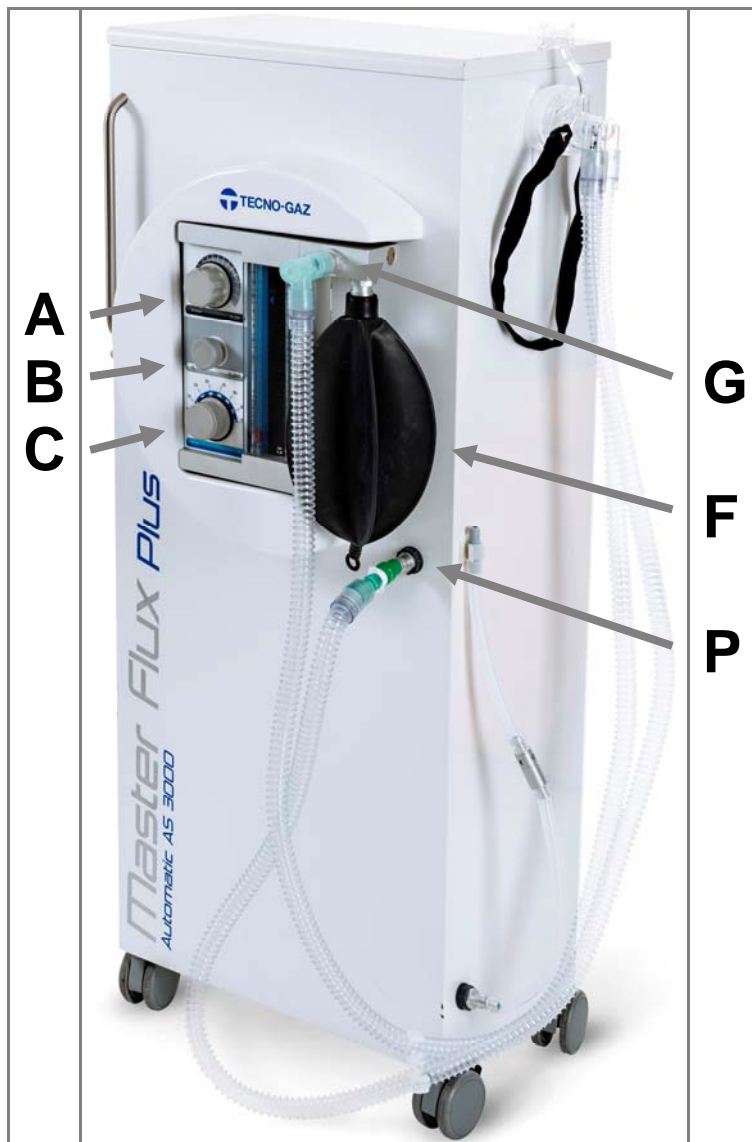
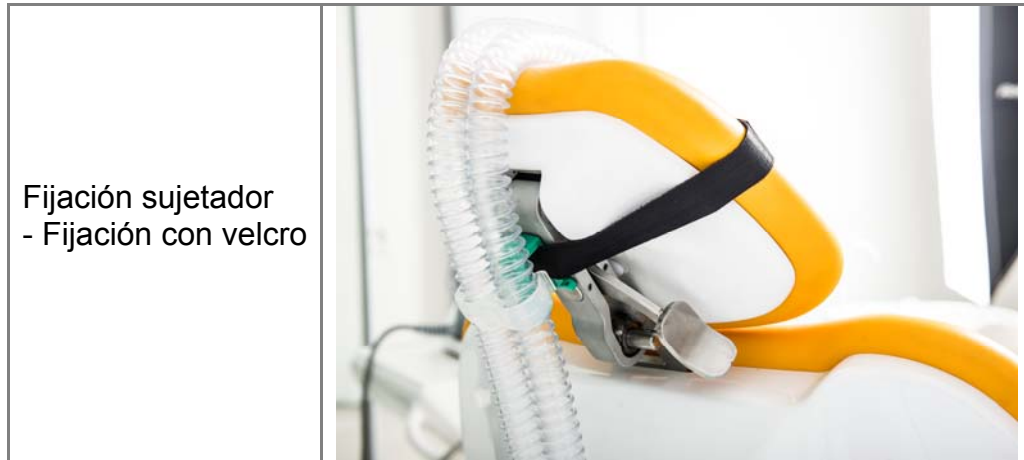

EVACUACIÓN DE LOS GASES QUE SE EMANAN

El operador puede elegir la solución del tratamiento de los gases que el paciente emana, utilizando las siguientes conexiones:

DESCARGA PASIVA	
MASTER FLUX CON MUEBLE	MASTER FLUX DE PARED
<p>Conecte el tubo de descarga del gas del circuito mascarilla, a la boquilla en el mueble.</p> <p>Conecte el circuito SMFA197, a la boquilla en el mueble.</p> <p>Coloque en el exterior del estudio el extremo del tubo espiralado y verifique la presencia del filtro final. La descarga se debe realizar en un lugar abierto y bien ventilado.</p>	<p>Conecte el tubo de descarga del gas del circuito en la boquilla correspondiente.</p> <p>Coloque en el exterior el extremo del tubo espiralado y verifique la presencia del filtro final.</p> <p>La descarga se debe realizar en un lugar abierto y bien ventilado.</p>
	

SCARICO ATTIVO

MASTER FLUX CON MUEBLE

MASTER FLUX DE PARED

Conexión al aspirador quirúrgico
 Conecte el circuito MF824ZMF
 Conecte el circuito a la aspiración quirúrgica.

Collegare il circuito MF824ZMF al circuito di scarico.
 Collegare il terminale all'aspiratore.

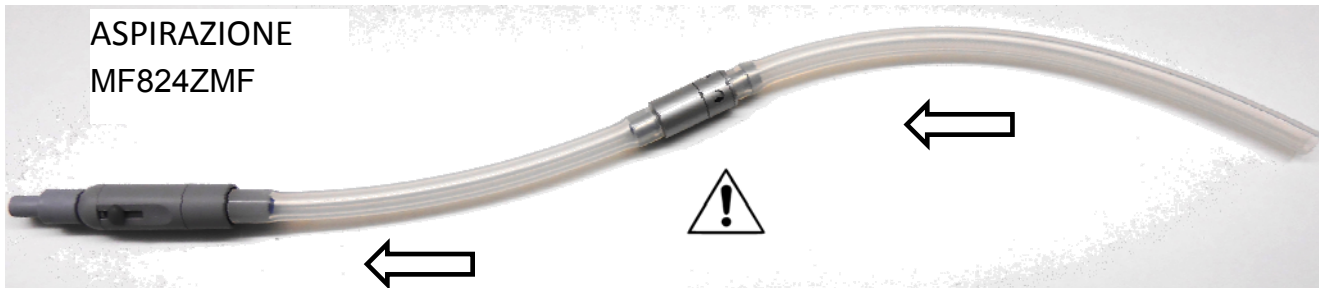

ASPIRAZIONE
 MF824ZMF

REGULACIÓN DE LA VÁLVULA

Gire la abrazadera perforada de la válvula (SMFA236) hasta que se cierren los agujeros.

Inicie el suministro del OXÍGENO configurando ~10 NI/min.

Ponga en marcha el aspirador quirúrgico configurando el valor de aspiración mínimo.

Observe LA BOLSA ANESTESIA.

Gire la abrazadera perforada de la válvula abriendo progresivamente los agujeros hasta obtener el estado ideal de la bolsa de anestesia "MEDIO LLENO MEDIO VACÍO".

ATENCIÓN

Si se varían los FLUJOS suministrados, puede ser necesario regular los flujos de aspiración correctos de los gases que se emanan.





Utilice detergentes no agresivos para materiales plásticos.

Limpie las superficies del dispositivo con un trapo limpio.

Antes y después de usarlo, limpie con detergente o esterilice las piezas en contacto con el paciente o con su respiración.

Tabla de limpieza de los componentes del MASTER FLUX

CÓDIGO	DESCRIPCIÓN	MATERIAL	ESTERILIZACIÓN	DESINFECCIÓN
			VAPOR	SALES CUATERNARIAS
CM84001	BOLSA DE ANESTESIA	GOMMA (NO LATEX FREE)	NO	SI
MF820ZMF	CIRCUITO	PVC	NO	NO
	MASCARILLAS	PC+SILICONA	T134	SI
	FASCIA NUCALE	VELCRO	NO	NO
SMFA236	VÁLVULA ELIMINACIÓN DE LOS GASES	AL + SILICONA	T134	SI
SMFA197	CIRCUITO DE DESCARGA	PVC + AL	NO	NO

ENSAMBLAJE DE LA MASCARILLA

Luego de la limpieza del dispositivo, ensamble la mascarilla.

**ATENCIÓN A LA DIRECCIÓN DE LOS FLUJOS
ELLOS SON ESTAS VÁLVULAS UNIDIRECCIONALES
ENLAZAR EL FLUJO EN LA DIRECCIÓN INDICADA**

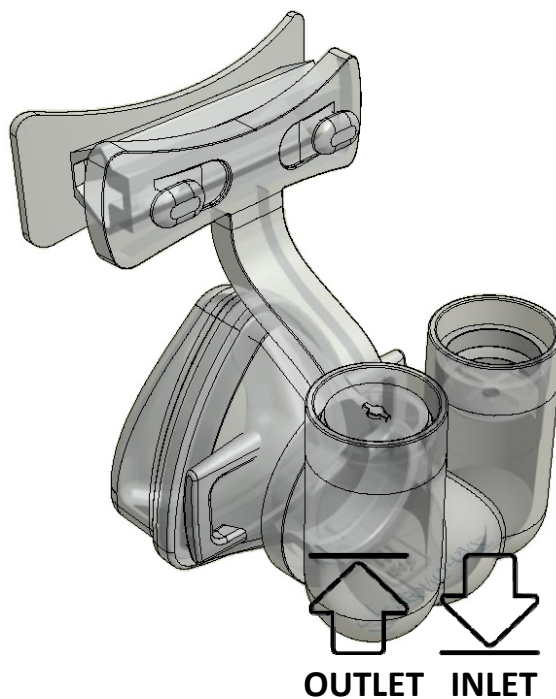

Circuito ENTRADA



INLET



Circuito SCARICO

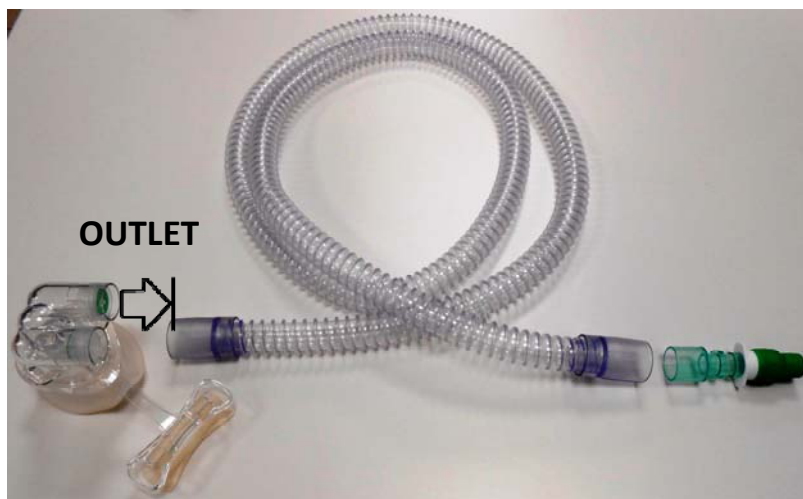

OUTLET



Identificación del circuito de gas exhalado



Para facilitar la identificación del circuito de descarga durante el montaje del circuito-mascarilla se han previsto dos anillos azules (Cod. 1ZMFA0082) Figuras A B C B muestran cómo utilizar los anillos. El indicador puede esterilizarse en autoclave.



ÍNDICE

1. DESTINO DE USO
3. CONEXÕES
4. LIMPEZA

1 DESTINO DE USO

Os circuitos e as máscaras Tecno-gaz são acessórios do dispositivo Master Flux e devem ser utilizados exclusivamente com o dispositivo Master Flux para o fornecimento de gases medicinais ao paciente.

A TECNO-GAZ não se responsabiliza se os circuitos e as máscaras forem utilizados em modo diverso daquele indicado.



A TECNO-GAZ não se responsabiliza por uso impróprio de circuitos e máscaras.

As máscaras são vendidas separadamente de MASTER FLUX, APENAS E EXCLUSIVAMENTE COMO PEÇAS DE REPOSIÇÃO DO DISPOSITIVO.





Componentes CICUITO:

<p>MF820ZMF</p>	<p>CIRCUITO COMPLETO</p>	
<p>MF835ZMF</p>	<p>MÁSCARA dimensão 1</p>	
<p>MF836ZMF</p>	<p>MÁSCARA dimensão 2</p>	
<p>MF837ZMF</p>	<p>MÁSCARA dimensão 3</p>	
<p>MF838ZMF</p>	<p>MÁSCARA dimensão 4</p>	
<p>SMFA197</p>	<p>CIRCUITO DE DESCARGA PASIVO</p>	
<p>MF824ZMF</p>	<p>CIRCUITO DE ASPIRAÇÃO CENTRALIZADA</p>	

Il circuito **MF824ZMF** è composto da:

TERMINAL ASPIRAÇÃO	
REDUÇÃO PARA SUCÇÃO DE SALIVA	
REDUCTION FOR SUCTION SALIVA	

O circuito **MF820ZMF** é composto por:

Ligação da conexão da caixa fluxométrica ▶ Conector 22 M/F 90°	
Dois tubos com 1.8 m de comprimento (material em PVC/PE) ▶ Tubo transparente e flexível. ▶ Tubo ondulado (espiral rígida) no lado externo (antiesmagamento) e liso no lado interno para proporcionar baixa adesão e ruído. ▶ Conectores terminais flexíveis para fácil adaptação.	
Ligação da conexão de descarga (material: stirolux) ▶ Redução 22-15	
Redução da conexão de descarga (material: TPE, PP) ▶ Conector elastomérico 9-11 mm	

Clipe de suporte de tubos e faixa em velcro ▶ Permite posicionar corretamente os tubos. A clipe adesiva pode ser fixada atrás do apoio de cabeça da poltrona ou através da respetiva faixa em velcro que pode ser posicionada neste mesmo apoio sem uma fixação vinculante. ▶ Permite um posicionamento fixo ou com movimento rotatório, segundo as próprias exigências.	
--	---

A máscara é composta por:

<p>Kit Máscara nasal Apoio para a testa Cód. 2ZMFA0050 dimensão 1 Cód. 2ZMFA0051 dimensão 2 Cód. 2ZMFA0052 dimensão 3 Cód. 2ZMFA0054 dimensão 4 (material: silicone) ▶ Permite reduzir as emissões de N2O no ambiente. ▶ Oferece um posicionamento confortável da máscara.</p>	
<p>Invólucro (material: PC) ▶ Transparente</p>	
<p>Suporte para a testa pequena (material : PC) ▶ Transparente Para dimensão 1 e de dimensão 2</p>	
<p>Suporte para a testa grande (material : PC) ▶ Transparente Para o dimensão 3 e de dimensão 4</p>	
<p>Ligação Y (PC) com válvulas (PC/silicone) ▶ Permite o fluxo correto da mistura de gás impedindo o retorno dos gases exalados ao circuito de alimentação. ▶ A pequena câmara elimina o risco de permanência de CO₂</p>	
<p>FAIXA PARA A NUCA GANCHO ▶ Permite estabilizar a máscara e regular o comprimento ideal para o paciente através das extremidades em velcro.</p>	

INSTRUÇÕES DE CONEXÃO

Controlar a integridade dos componentes.

Escolher uma máscara idónea ao paciente.

Posicionar a máscara e regular a faixa para a nuca. A máscara deve ser estável e confortável para o paciente.

Conectar os tubos prestando atenção à seta situada na conexão em "Y". A seta indica a direção do fluxo. As válvulas de retenção situadas na conexão direcionam o fluxo do gás na direção indicada pela seta.

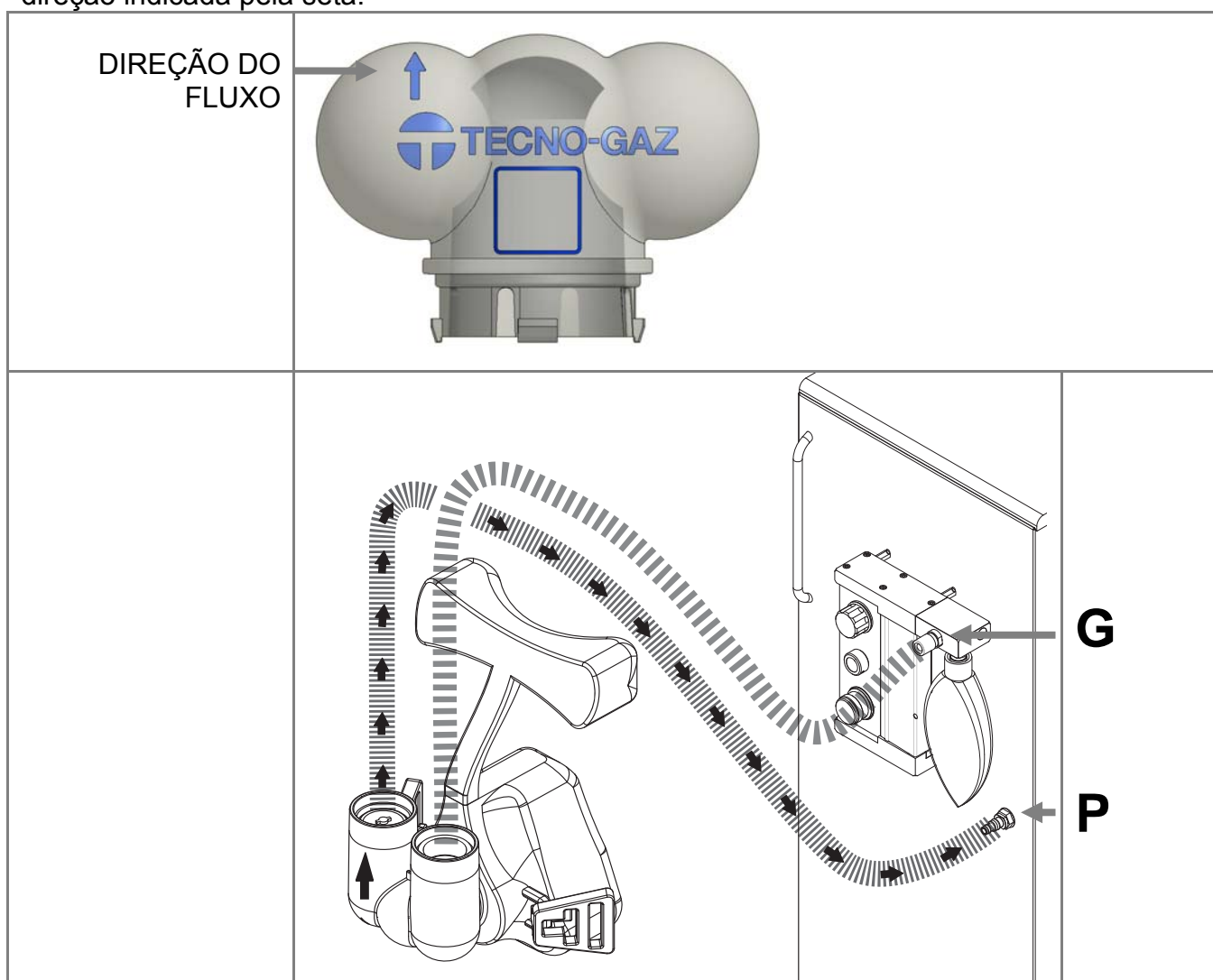

Conectar a ligação livre a 90° do tubo de alimentação do respetivo porta-borracha (Pos. G) do módulo distribuidor.

Conectar a extremidade livre através do conector elastomérico ao porta-borracha presente no móvel.

Fixar a clipe para estabilizar os tubos atrás do apoio de cabeça da poltrona.
É possível fixar através de adesivo (fixo) ou através do respetivo velcro fornecido (móvel).

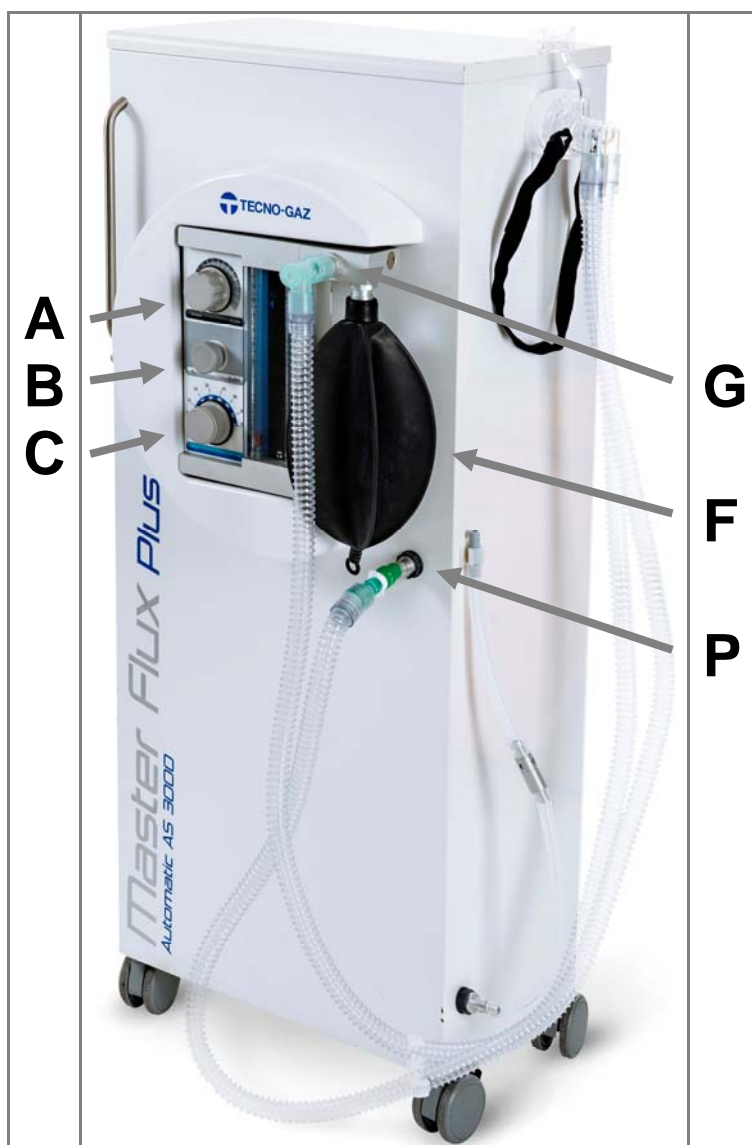
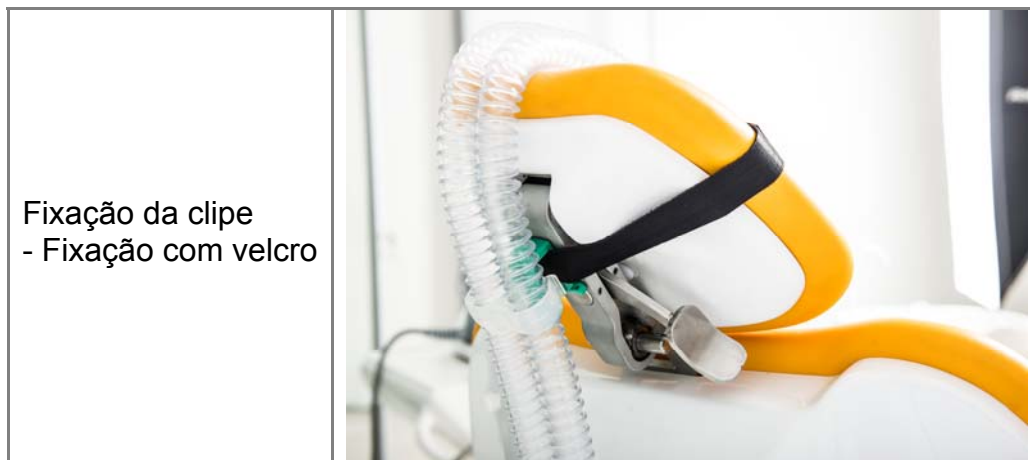

EVACUAÇÃO DOS GASES EXALADOS

O operador pode escolher a solução do tratamento dos gases exalados pelo paciente utilizando as seguintes conexões:

DESCARGA PASSIVA	
MASTER FLUX DE MÓVEL:	MASTER FLUX DE PAREDE:
<p>Conectar o tubo, de descarga do gás do circuito da máscara, ao porta-borracha no móvel.</p> <p>Conectar o circuito SMFA197 ao porta-borracha no móvel.</p> <p>Colocar a extremidade do tubo em espiral no lado externo no lado externo do consultório e controlar se o filtro final está instalado. A descarga deve ser realizada em local aberto e bem ventilado.</p>	<p>Conectar o tubo de descarga do gás do circuito ao respetivo porta-borracha.</p> <p>Colocar a extremidade do tubo em espiral no lado externo e controlar se o filtro final está instalado.</p> <p>A descarga deve ser realizada em local aberto e bem ventilado.</p>
	

DESCARGA ATIVA

MASTER FLUX DE MÓVEL:

Conexão ao aspirador cirúrgico
Conectar o circuito MF824ZMF.
Conectar o circuito à aspiração cirúrgica.

MASTER FLUX DE PAREDE:

Ligar o circuito MF824ZMF ao circuito de descarga.
Ligue o terminal do aspirador.

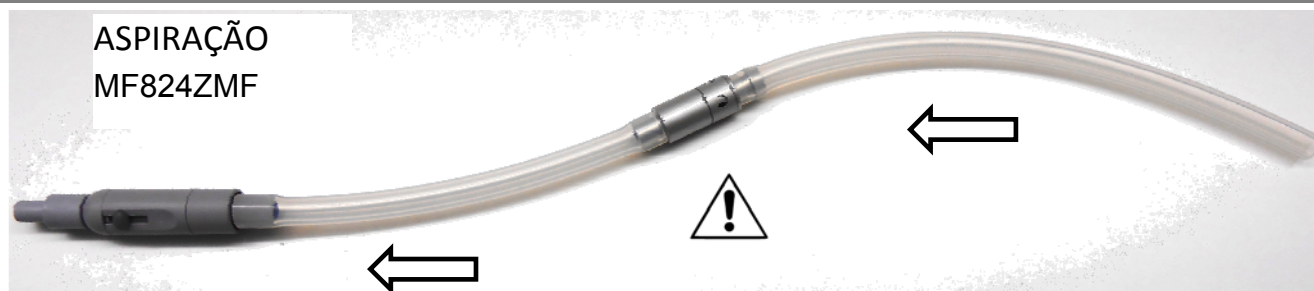

REGULAÇÃO DA VÁLVULA

Girar a virola perfurada da válvula (SMFA236) até o fechamento dos furos.

Ativar o fornecimento de OXIGÉNIO configurando ~10 NI/min.

Ativar o aspirador cirúrgico e configurar o valor mínimo de aspiração.

Observar o BALÃO DE ANESTESIA.

Girar a virola perfurada da válvula abrindo progressivamente os furos até obter o estado ideal do balão de anestesia em condição "MEIO CHEIO/MEIO VAZIO".

ATENÇÃO:

Com o alterar de FLUXOS distribuídos, pode ser necessário regular os corretos fluxos de aspiração dos gases exalados.





Utilizar detergentes não agressivos para material plástico.

Limpar as superfícies do dispositivo com pano seco.

Antes e depois do uso, é necessário limpar, desinfetar ou esterilizar os elementos em contacto com o paciente ou com sua respiração.

Tabela de limpeza dos componentes MASTER FLUX

			ESTERILIZAÇÃO	DESINFEÇÃO
CÓDIGO	DESCRIÇÃO	MATERIAL	VAPOR	SAIS QUATERNÁRIOS
CM84001	BALÃO DE ANESTESIA	BORRACHA (NO LATEX FREE)	NO	SI
MF820ZMF	CIRCUITO	PVC	NO	NO
	MÁSCARAS	PC+SILICONE	T134	SI
	FAIXA PARA A NUCA	VELCRO	NO	NO
SMFA236	VÁLVULA ELIMINAÇÃO DE GÁS	AL + SILICONE	T134	SI
SMFA197	CIRCUITO DE DESCARGA	PVC + AL	NO	NO

MONTAGEM DA MÁSCARA

Montar a máscara após a limpeza do dispositivo.

**ATENÇÃO À DIREÇÃO DOS FLUXOS
ELES SÃO ESTAS VÁLVULAS UNIDIRECIONAL
VINCULAÇÃO O FLUXO NA DIRECÇÃO INDICADA**

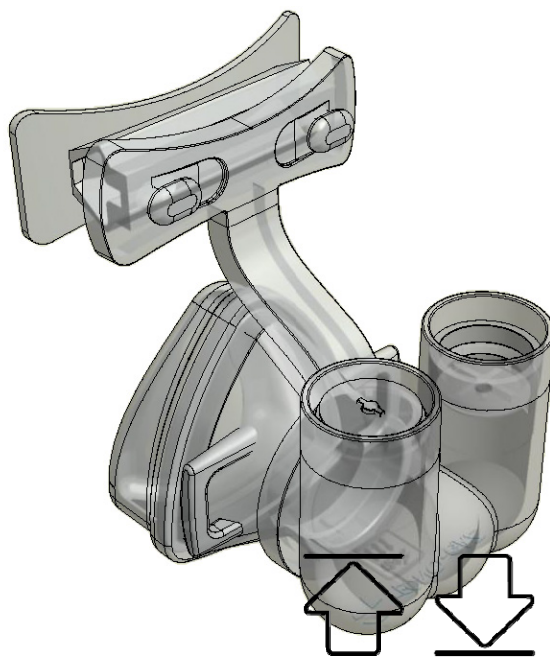

OUTLET INLET
(SAÍDA) (ENTRADA)



Entrada do circuito



INLET



DESCARGA circuito



OUTLET



Identificação do circuito de gás exalado



Para facilitar a identificação do circuito de descarga durante o modelo de circuito de montagem são fornecidos dois anéis azuis (Cod. 1ZMFA0082) Figuras A B C D mostram como usar os anéis. O indicador é autoclavável.





TECNO-GAZ S.p.A.

*Strada Cavalli N°4 • 43038
Sala Baganza • Parma • ITALIA
Tel. +39 0521 83.80
Fax. +39 0521 83.33.91*

www.tecnogaz.com

P
E
D
E
N
I

Il presente manuale deve sempre accompagnare il prodotto, in adempimento alle Direttive Comunitarie Europee. TECNO-GAZ, si riserva il diritto di apporre modifiche al presente documento senza dare alcun pre-avviso. La ditta TECNO-GAZ si riserva la proprietà del presente documento e ne vieta l'utilizzo o la divulgazione a terzi senza il proprio benestare.

This manual must always be kept with the product, in complying with the Directives of European Community. TECNO-GAZ reserves the right to modify the enclosed document without notice. TECNO-GAZ reserves the property of the document and forbids others to use it or spread it without its approval.

Diese Anleitung muss dem Gerät in Übereinstimmung mit den Richtlinien der Europäischen Gemeinschaft beigelegt werden. TECNO-GAZ behält sich dar Recht vor ohne Vorankündigung Änderungen in dieser Dokumentation vorzunehmen. Die Firma TECNO-GAZ ist Eigentümer der vorliegenden Dokumentation und verbietet die Nutzung von Dritten oder die Weitergabe an Dritte ohne entsprechende Genehmigung.

El presente manual siempre deberá acompañar el producto al cual pertenece, cumpliendo las Directivas Comunitarias Europeas. TECNO-GAZ, reserva el derecho de aportar alteraciones al presente documento sin avisos previos. La empresa TECNO-GAZ reserva a sí los derechos de propiedad del presente documento prohibiendo su utilización o divulgación a terceros sin que haya expresado su consentimiento.

Este manual deve estar junto do equipamento, em consonância com as Directivas da Comunidade Europeia. TECNO-GAZ reserva o direito de modificar este manual sem aviso prévio. TECNO-GAZ reserva a propriedade do documento e proíbe o uso a terceiros ou publicação sem a sua aprovação prévia.